

1 Pullman Chair with Legs

# pullman

Chair



2 Pullman Chair with Upholstered Swiveling Plinth



Pullman Chair designed by naughtone 2020

### About Pullman Chair

The Pullman chair is part of the wider Pullman range of high back seating products. The Pullman range functions as an attractive private retreat or group collaboration space, on an economical footprint.

Pullman chair is a unique single user privacy seat that acts as an acoustic haven for individual working or retreating. When specified with an upholstered swiveling plinth, users are able to retreat away from disruption, even further, allowing private conversations, work or relaxation to remain private.

The unique integrated tablet provides an opportunity for users to work within the space for longer periods of time, maintaining comfort.

### Compliance

- SCS Indoor Advantage™ Gold Certificate
- FSC®certified products available upon request
- naughtone is FISP and ISO14001 certified
- Our seating is designed to meet or exceed all EN performance requirements per BS EN 16139:2013

### Sizes

All dimensions quoted are rounded to the nearest 5mm or nearest 1/2 inch

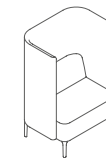

**PUL15H**  
Pullman Chair with Legs  
mm W 900 D 675 H 1300 Seat 450  
inch W 35.5 D 26.5 H 51 Seat 18

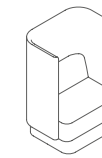

**PUL15HPL**  
Pullman Chair with Upholstered Plinth  
mm W 900 D 675 H 1300 Seat 450  
inch W 35.5 D 26.5 H 51 Seat 18

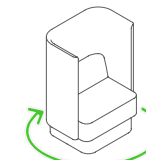

**PUL15HSW**  
Pullman Chair with Upholstered Plinth  
mm W 900 D 675 H 1300 Seat 450  
inch W 35.5 D 26.5 H 51 Seat 18

### Table Top Options



**White / Black MFMD**  
with reverse chamfer,  
polished MDF edge



**Oak Veneer**  
with reverse chamfer,  
polished MDF edge



**Walnut Veneer**  
with reverse chamfer,  
polished MDF edge

### Leg Finishes

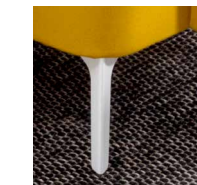

**White / Black Steel Legs**  
Standard

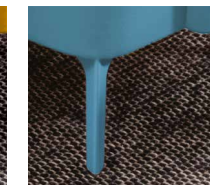

**RAL Powder Coated Legs**  
naughtone Colours



**Solid Oak Legs**



**Solid Walnut Legs**

### Other Options

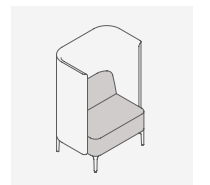

**Two Tone Sofa**  
Outer screen / seat & backrest

### Accessories



**Scatter Cushion**



**Power and Data**

### Tablet Arm & Power

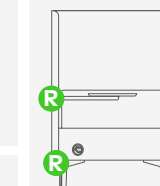

**Chair**  
Right hand side only



















# Pullman Chair Technical Specifications

## Testing

Our seating is designed to meet or exceed all EN performance requirements per **EN16139:2013**, which includes the following tests:

- Seat and back static load test
- Seat and back durability test
- Seat front edge static load test
- Seat front edge durability test
- Vertical static load on back
- Leg forward static load test
- Foot rest and leg rest static load test
- Leg sideways static load test
- Arm sideways static load test
- Seat impact test
- Arm downwards static load test
- Back impact test
- Vertical upwards static load on arm rests
- Arm impact test

## Structural Testing Certifications

**PUL15H**  
Pullman Chair with Legs and Tablet  
**BS EN 16139, 2013, Level 2**  
Static Load 200kg  
**ANSI/BIFMA X5.4 - 2012**  
Static Load 300lbs

## Flammability

The cold cure foam material has been tested to meet the following standards:

British standard **5852:2006 Part 2**

California Technical Bulletin **117-2013**

Italian standards quoted are rounded to the nearest 5mm or nearest 1/2 inch  
**UNI 9175-CLASS 1.IM**

The flammability standard of the covering fabric is dependent on the choice made by the customer, details of the flammability rating of specific fabrics can be found on supplier's websites listed below.

- [www.kvadrat.dk](http://www.kvadrat.dk)
- [www.camirafabrics.com](http://www.camirafabrics.com)
- [www.butefabrics.com](http://www.butefabrics.com)
- [www.panaz.com](http://www.panaz.com)
- [www.maharam.com](http://www.maharam.com)
- [www.vescom.com](http://www.vescom.com)
- [www.ultrafabricsllc.com](http://www.ultrafabricsllc.com)
- [www.crestleather.com](http://www.crestleather.com)

## Servicing



If a component is damaged and needs replacing then please email our team with an image of the damaged part and reference your order number, we will be happy to facilitate any replacements.

## Warranty



naughtone offers a **7 Year** warranty across all products. Details on the terms and conditions of naughtones warranty can be found at [naughtone.com/warranty](http://naughtone.com/warranty)

# Pullman Chair Technical Specifications

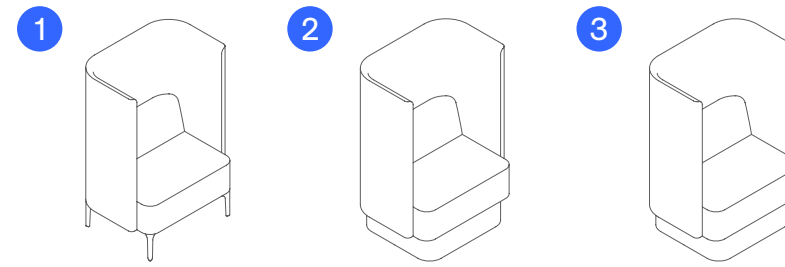

Product Code and Description <small>All dimensions quoted are rounded to the nearest 5mm or nearest 1/2 inch</small>	A Width Overall	B Depth Overall	C Height Overall	D Seat Height Floor to top of seat	E Seat Width	F Height from Seat to Top	G Surround Thickness	H Tablet Diameter	I Weight
<b>1 PUL15H</b> Pullman Chair with Legs	900 mm 35.5 in	675 mm 26.5 in	1300 mm 51 in	450 mm 18 in	800 mm 31 in	850 mm 34 in	60 mm 2 in	350 mm 14 in	47.2 kg 104 lbs
<b>2 PUL15HPL</b> Pullman Chair with Upholstered Plinth	900 mm 35.5 in	675 mm 26.5 in	1300 mm 51 in	450 mm 18 in	800 mm 31 in	850 mm 34 in	60 mm 2 in	350 mm 14 in	53.5 kg 118 lbs
<b>3 PUL15HSW</b> Pullman Chair with Upholstered Swivelling Plinth	900 mm 35.5 in	675 mm 26.5 in	1300 mm 51 in	450 mm 18 in	800 mm 31 in	850 mm 34 in	60 mm 2 in	350 mm 14 in	60.1 kg 133 lbs

## Measuring Guide

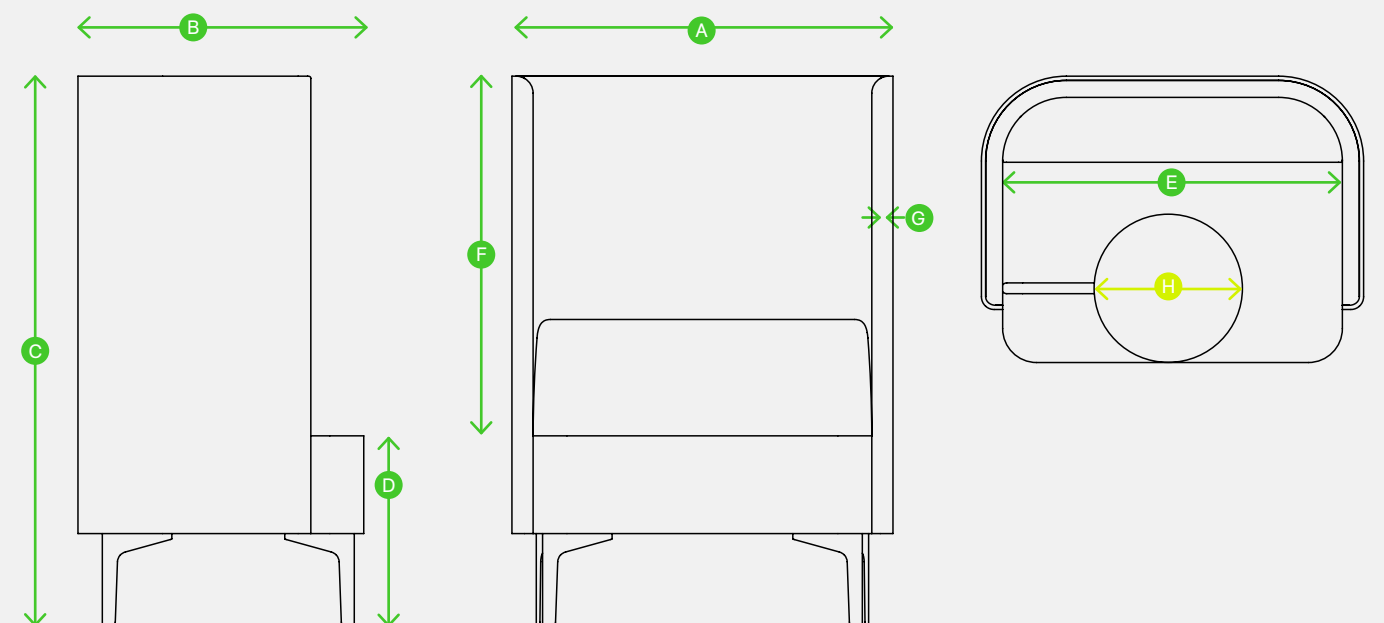



# Pullman Chair Environmental Product Summary



## Environment Attributes

- naughtone is **FISP** and **ISO14001** certified
- naughtone is **FSC®** certified
- **42.7kg** total weight
- **15.7% Recyclable** (foam, fixings, legs, brackets and plastic fixtures)
- **71.3% Reusable** (frame, table top)
- **23.2% Recycled Content** (foam, fixings, legs, brackets, plastic fixtures and table top)
- **Indoor Advantage™ Gold** ANSI/BIFMA Furniture Emissions Standard (M7.1/X7.1-2011 R2016) and ANSI/BIFMA e-3-2014e (Credits 7.6.1, 7.6.2, 7.6.3)

These attributes can help you to achieve criteria towards **LEED, BREEAM, Ska** and **WELL** building certifications



# Pullman Chair Environmental Product Summary

## Material Percentage Split

- 47.3% Birch Plywood
- 14.9% MDF
- 13% Fabric
- 9% Particleboard
- 7.3% Mild Steel
- 6.5% CMHR Foam
- 1% Mild Steel Zinc Plated
- <1% Stainless Steel
- <1% Polypropylene
- <1% Polyethylene

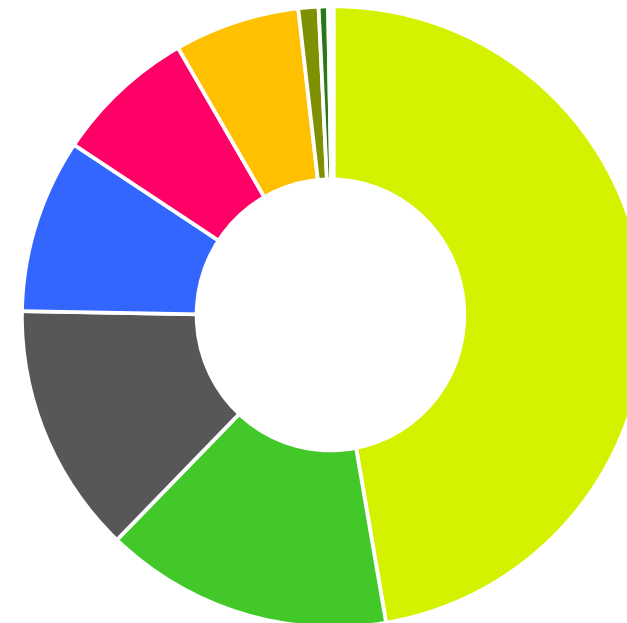

## Post Consumer Recycled Content

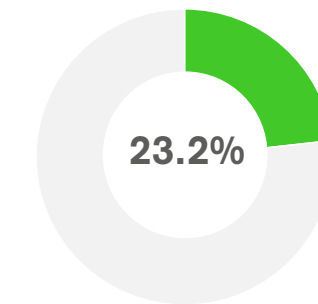

## Recyclable Content

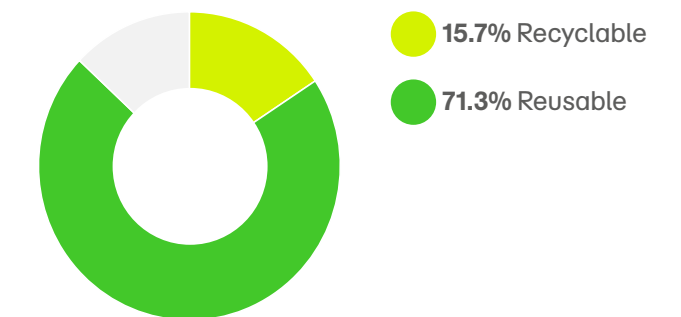

## Product Specific Design Statement

The Pullman Chair is available in a range of finishes but for the purpose of this document we have a specific example from the range:

### Pullman Chair with Steel Legs and Tablet

The Pullman Chair frame is constructed from plywood and particle board then topped with CMHR foams before being upholstered.

The Pullman Chair legs are made from laser cut folded mild steel with the individual laser cut components being folded allowing for minimal additional welding. The legs are finished with a zinc primed polyester powder coat.

The tablet top is CNC cut from white Melamine Faced Medium-density fibreboard, with the raw edge polished and finished with a hard-wearing spray lacquer.

## CSR Statement

naughtone has always considered the environment throughout our design and manufacturing process. We understand that as we continue to grow, so does our potential impact on our surroundings. As most of our raw materials are simple, we have great control over their sources, and are proud to be able to offer **FSC®** certified upholstered products and use recycled metals in our table ranges. The addition of our North American manufacturing provision also helps to keep manufacturing miles to a minimum, as our market continues to grow in the USA. Finally, naughtone offers a 'bring back' programme, where the client is able to return the product to our factory, where we will be happy to breakdown and recycle the parts for you.

Where sustainable sources are quoted, and a chain of custody is required by a customer this must be indicated on the purchase order to naughtone. A chain of custody requested after an order has been placed or delivered may be difficult to recover.

Figures stated in the Environmental product summary may vary based on model and options selected, we have based this document on a specific example when produced in the United Kingdom. Recycled content calculations are taken from supplier information and industry averages, material variables are likely to affect the figures which may result in higher or lower percentages.

This document will be reviewed and updated periodically and is subject to change without notice.



FSC® certified products available upon request



naughtone offers PEFC certified products





### 1 Design

Every aspect of the naughtone product ranges has been designed with the environment considered, from ethical material choice and production efficacy to storage efficiency and ease of disassembly.

Dense foam sets and resilient fabrics are selected for their longevity and effectiveness across sectors. Durable high quality finishes such as powder coated bases in a range of colours allow clients the freedom of finish options. Finish samples are available allowing clients to make informed decisions and retain to add to their finish libraries for future reference.

### 2 Raw Material

Local supply of raw materials is employed for the production of our products when possible, procured from suppliers that are quality inspected for extraction methods and meet the highest environmental standards.

### 3 Production

As many of our products are assembled by hand the energy expenditure wasted from machinery during the production process is kept to a minimum.

All fabrics are cut to ensure optimum efficiency with fabric usage and reduced waste consumption per unit.

All production sites have recycling facilities for any excess product that cannot be used elsewhere, which is then managed by a professional third party.

### 4 Distribution

Distribution of naughtone products generally occurs directly between the manufacturing site to the client. Production is localised when possible to the US or UK regions, reducing the carbon footprint and miles travelled for each product.

Many items are flat packed for delivery or shipped disassembled with efficient, minimised packaging; optimizing the transportation vessel space.

### 5 Usage

naughtone products do not require energy or water to function, thus no environmental exchange takes place and no waste is generated during the life of the product.

The only foreseeable need is the cleaning of the product for general maintenance. This includes regular vacuuming to remove dirt and dust particles on upholstery items, and using a dry or damp cloth to wipe non-upholstery items.

This is recommended for all products utilised under conditions of normal wear and is expected to have negligible environmental impacts.

### 6 End of Life

Although our products are durable and demonstrate timeless design, naughtone products are manufactured in such a way that they can be easily disassembled at the end of life and most of the componentry can be either recycled or re-used as applicable.

As a company we are also happy to accept the return of products, to help re-home or recycle furniture or components at the end of the products useful life.

#### UK Showroom

6 Bakers Yard  
Clerkenwell  
London EC1R3DD  
T: +44 (0)20 389 22 788

#### US Showroom

Suite 11-88  
222 Merchandise Mart Plaza  
Floor 11  
Chicago IL 60654

#### naughtone HQ

Knaresborough Tech Park  
Manse Lane  
Knaresborough HG5 8LF

T: +44 (0) 1423 816 500  
E: sales@naughtone.com

[www.naughtone.com](http://www.naughtone.com)