

# High Nest Sofa



**+Halle®**

## High Nest Sofa

The High Nest Sofa is a soft, inviting and comfortable high sofa that literally takes the traditional lounge area to new heights. The High Nest Sofa boldly challenges the conventions of the bar stool and sofa, melting the two together to create the beautiful, upholstered high seat. The vertical nest is inspired by the way people interact with furniture in public spaces, encouraging a more social atmosphere. The high sofa is specially crafted for just the right amount of steadiness and elegance, balancing the two to create warm, inviting and comfortable seating arrangements. Steel frame available in black or grey. Part of the Nest series that comprises chairs, sofas and tables in two heights. Available in all types of textiles and leather types.

### Designed by Form Us With Love

Form Us With Love was founded in 2005 and since its conception, the studio has burned with a passion for design and its democratic potential. Its belief is that we all have a right to meaningful design. At the studio's core lies a process that blends traditional creative practices with a lean, strategic application. The central intention is to evolve with the needs of each project, its place in the market, and the ever-changing needs of real people.



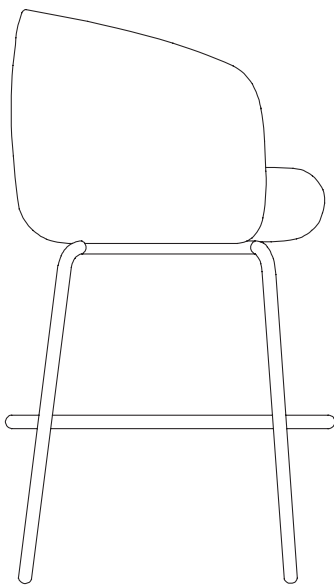

107

60

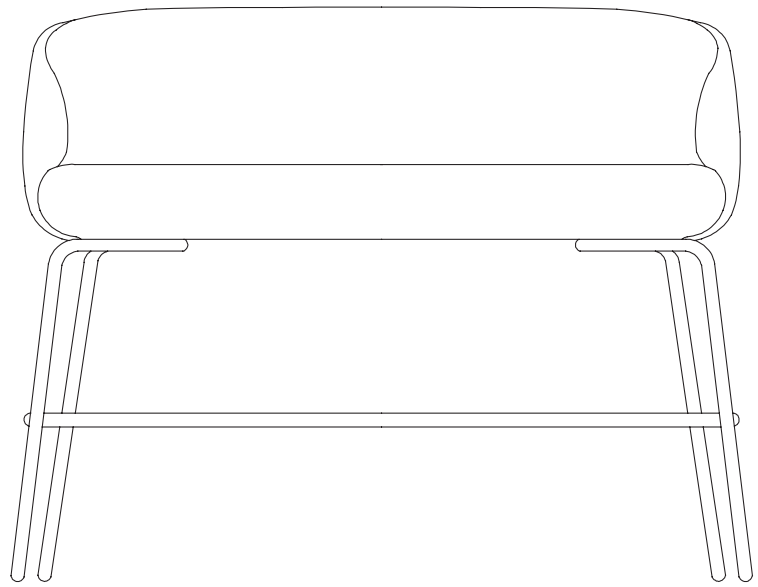

78

137

Dimensions defined in centimeters

---

**Design**

Form Us With Love

**Materials**

High quality moulded foam. Legs in black RAL 9005 / light gray RAL 7035 powder coated steel

**Fabric**

Available in all textiles and leather types

## Notes

A large grid of small dots for taking notes, consisting of 20 columns and 30 rows.

## Creating human spaces

**+Halle is a Danish high quality design furniture brand. We strive to add value to public areas by contributing to the creation of Human Spaces. The basic idea behind +Halle can be put down to a basic understanding of people.**

# Low Nest Sofa



**+Halle®**



## Low Nest Sofa

The Low Nest Sofa is a soft and comfortable sofa that suits the needs of a large variety of public spaces. The soft curves and fluid intersection between the seat and the backrest underlines the sofa's quality in terms of design and production, providing a distinct Nordic expression that adds a contemporary and modern feel to all kinds of spaces. Part of the Nest series that also contains chairs, sofas and tables in two heights. Comes with a frame in black or grey powder coated steel. Available in all kinds of textiles and leather qualities.

### Designed by Form Us With Love

Form Us With Love was founded in 2005 and since its conception, the studio has burned with a passion for design and its democratic potential. Its belief is that we all have a right to meaningful design. At the studio's core lies a process that blends traditional creative practices with a lean, strategic application. The central intention is to evolve with the needs of each project, its place in the market, and the ever-changing needs of real people.

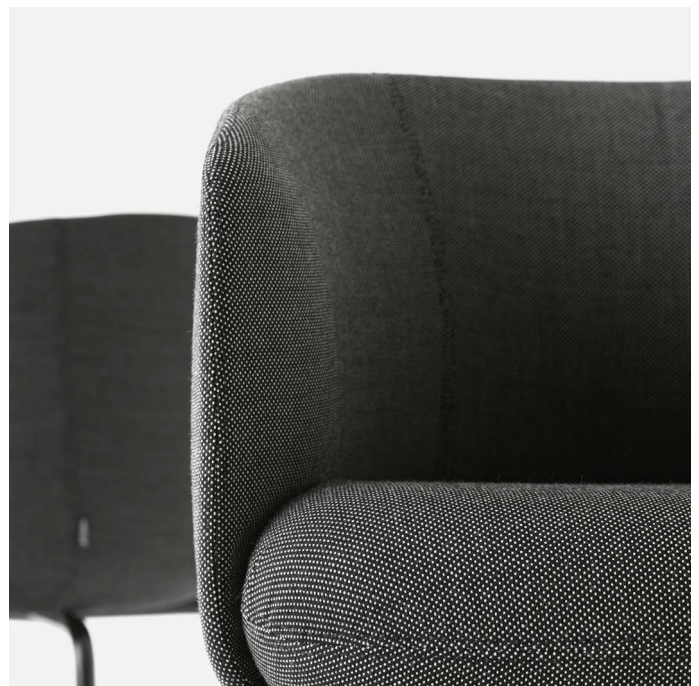

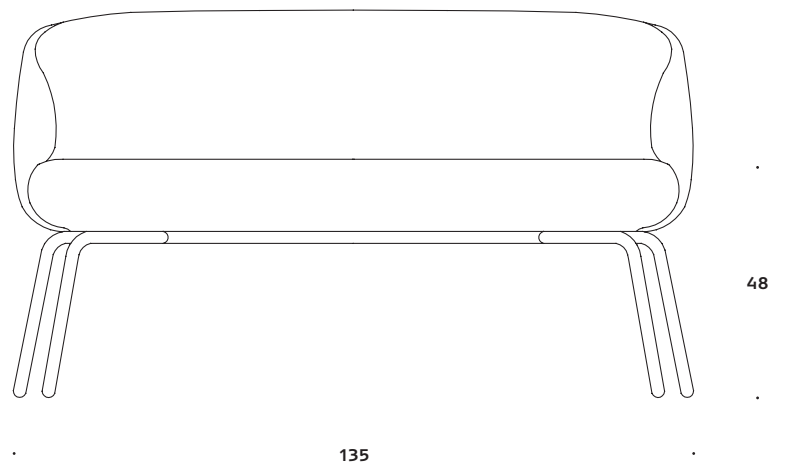
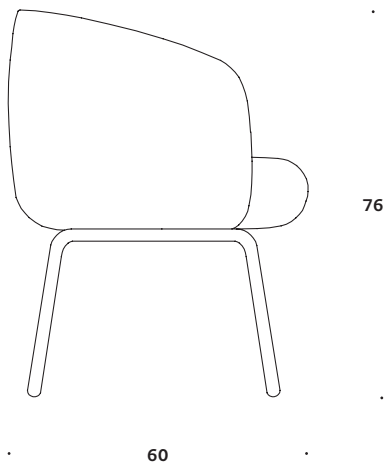

Dimensions defined in centimeters

---

**Design**

Form Us With Love

**Materials**

High quality moulded foam. Legs in black RAL 9005 / light gray RAL 7035 powder coated steel

**Fabric**

Available in all textiles and leather types

## Notes

A large grid of small dots for taking notes, consisting of 20 columns and 30 rows.

## Creating human spaces

**+Halle is a Danish high quality design furniture brand. We strive to add value to public areas by contributing to the creation of Human Spaces. The basic idea behind +Halle can be put down to a basic understanding of people.**



# Low Nest Sofa Wood



**+Halle®**

## Low Nest Sofa Wood

The Low Nest Chair is a compact and comfortable chair with a tight Nordic expression. The chair suits all kinds of modern spaces and provides a subtle yet distinct expression of Nordic quality and design. The chair is part of the Nest series that comprises chairs, sofas and tables in two heights, enabling the creation of dynamic and flexible spaces. Frame in solid soaped oak / solid black stained oak. Available in all textiles and leather qualities.

### Designed by Form Us With Love

Form Us With Love was founded in 2005 and since its conception, the studio has burned with a passion for design and its democratic potential. Its belief is that we all have a right to meaningful design. At the studio's core lies a process that blends traditional creative practices with a lean, strategic application. The central intention is to evolve with the needs of each project, its place in the market, and the ever-changing needs of real people.





135

78

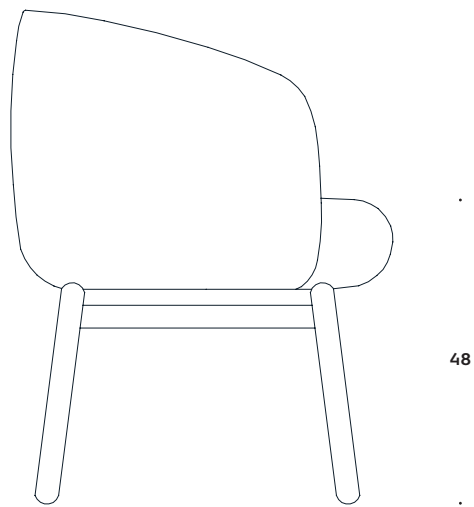

60

48

Dimensions defined in centimeters

---

**Design**

Form Us With Love

**Materials**

High quality moulded foam. Legs in solid soaped oak / solid black stained oak

**Fabric**

Available in all textiles and leather qualities

## Notes

A large grid of small dots for taking notes.

## Creating human spaces

**+Halle is a Danish high quality design furniture brand. We strive to add value to public areas by contributing to the creation of Human Spaces. The basic idea behind +Halle can be put down to a basic understanding of people.**

# Low Nest Chair Wood



**+Halle®**

## Low Nest Chair Wood

The Low Nest Chair is a compact and comfortable chair with a tight Nordic expression. The chair suits all kinds of modern spaces and provides a subtle yet distinct expression of Nordic quality and design. The chair is part of the Nest series that comprises chairs, sofas and tables in two heights, enabling the creation of dynamic and flexible spaces. Frame in solid soaped oak / solid black stained oak. Available in all textiles and leather qualities.

### Designed by Form Us With Love

Form Us With Love was founded in 2005 and since its conception, the studio has burned with a passion for design and its democratic potential. Its belief is that we all have a right to meaningful design. At the studio's core lies a process that blends traditional creative practices with a lean, strategic application. The central intention is to evolve with the needs of each project, its place in the market, and the ever-changing needs of real people.





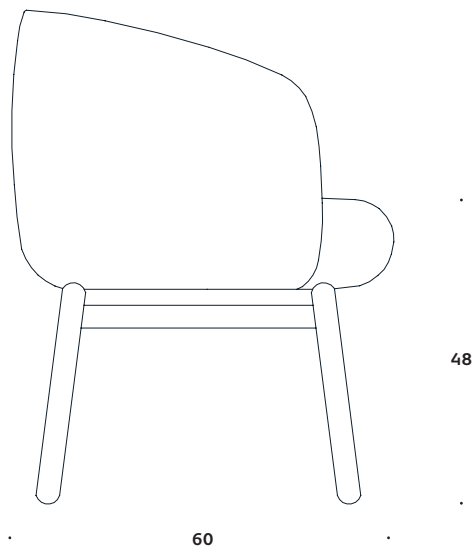
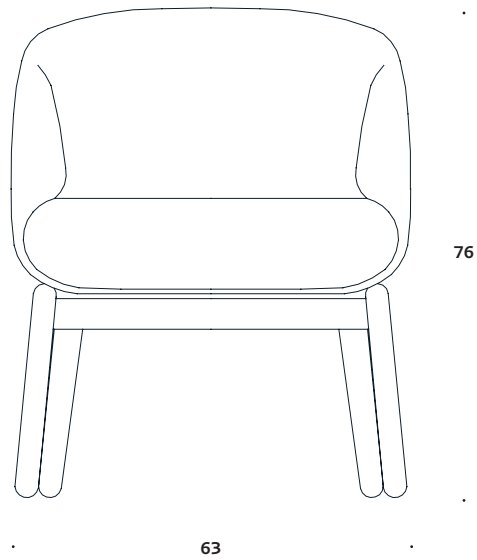

Dimensions defined in centimeters

---

**Design**

Form Us With Love

**Materials**

High quality moulded foam. Legs in solid soaped oak / solid black stained oak

**Fabric**

Available in all textiles and leather qualities



## Notes

A large grid of small dots for taking notes, consisting of 20 columns and 30 rows.

## Creating human spaces

**+Halle is a Danish high quality design furniture brand. We strive to add value to public areas by contributing to the creation of Human Spaces. The basic idea behind +Halle can be put down to a basic understanding of people.**