

ACCENT - CRAVACHE LAMP

Paulineplusluis

SERAX



In their characteristic style, design studio PaulinePlusLuis let experiment and production merge together with the Accent & Cravache lamps for Serax. The black rubber and fiberglass lighting and fastening wires are rigid but they still give way at the same time, similar to the

riding crop that the object is named after. With Accent & Cravache from PaulinePlusLuis for Serax you can easily create a unique and personal play of light, curves and lines, both on the ceiling and on the wall.

PAULINEPLUSLUIS



PaulinePlusLuis is a design studio based in Brussels, created by Pauline Capdo and Luis Bellenger in 2015. Their eclectic background, at the same time artisanal, artistic and industrial, has built their design approach that combines experiment and industry. Their work is based on the observation of objects, phenomena and moments that they interpret and transform. They are inspired by the shapes already belonging to our environment, which they put together and translate into their objects. Through this approach, their products give a sense of déjà vu, they refer to stories and moments, and can bring a poetic dimension to industrial production. An approach that is proving successful, because during the 2018 Milan Design Week, studio PaulinePlusLuis was one of the five 'New Belgians' who made their debut at the Salone Satellite.

ACCENT LAMP

Paulineplusluis

SERAX

PRODUCT INFO

Accent Lamp Straight
B7218533
136 cm

TYPE

Pendant Lamp

MATERIAL

Metal

CORD LENGTH

1,65m

SWITCH

No

LIGHT SOURCE

E27

MAX WATT

25 Watt

MAX VOLT

240 Volt

LAMP

Not included

CERTIFICATION

Class I

ENVIRONMENT

Indoor

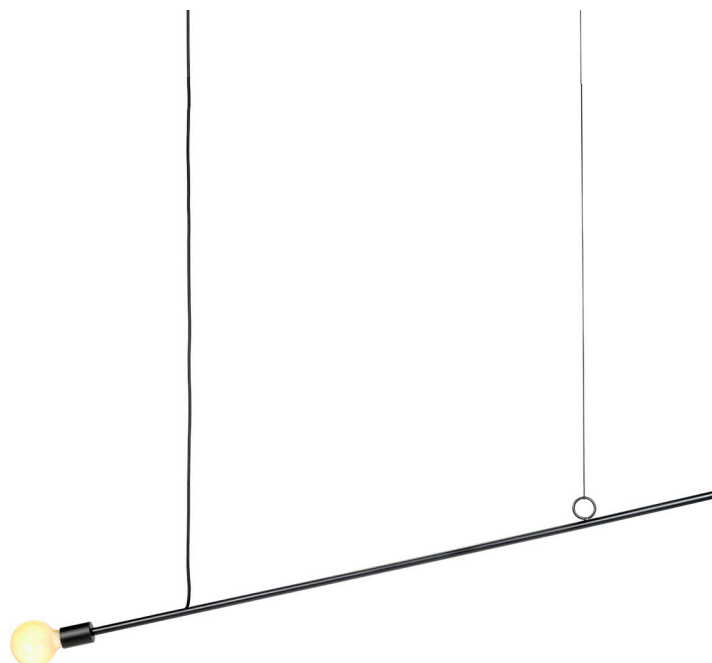
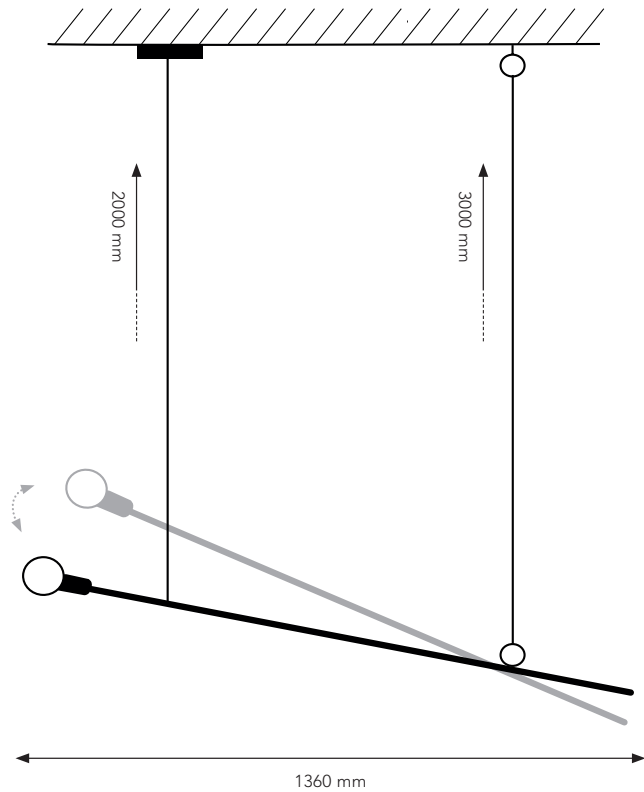
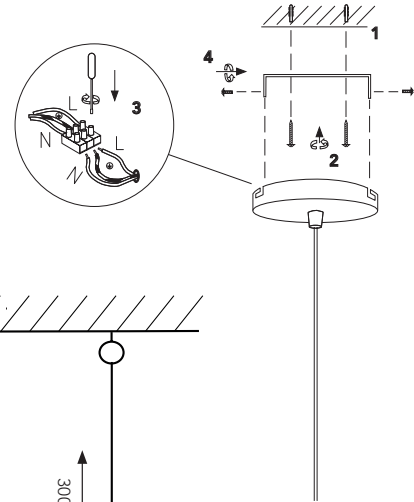

ACCENT LAMP

Paulineplusluis

SERAX

PRODUCT INFO

Accent Lamp Curved
B7218534
126 cm

TYPE

Pendant Lamp

MATERIAL

Metal

CORD LENGTH

1,65m

SWITCH

No

LIGHT SOURCE

E27

MAX WATT

25 Watt

MAX VOLT

240 Volt

LAMP

Not included

CERTIFICATION

Class I

ENVIRONMENT

Indoor

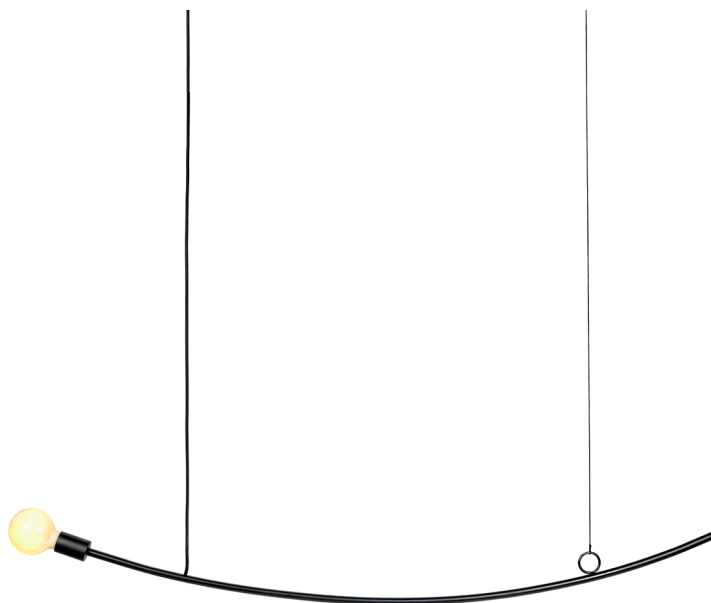
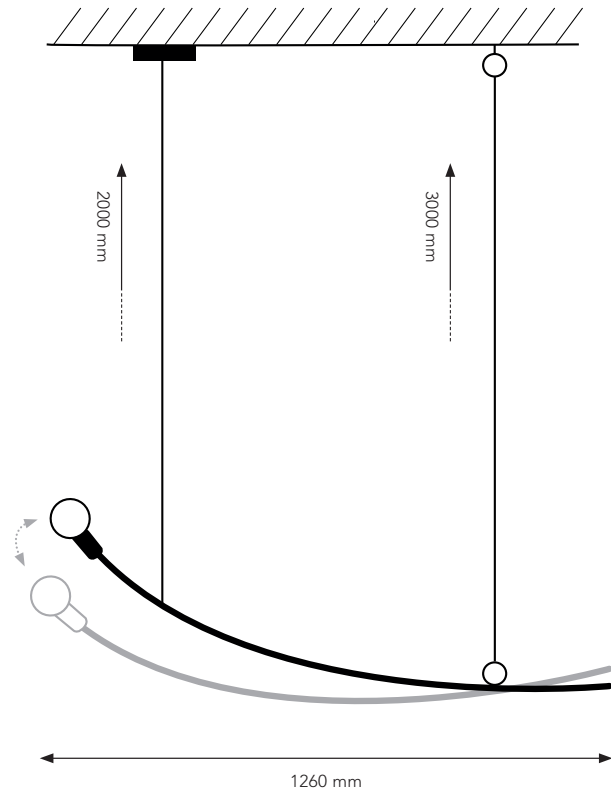
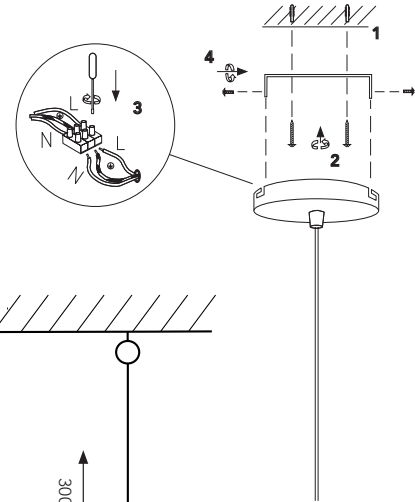

CRAVACHE LAMP

Paulineplusluis

SERAX

PRODUCT INFO

Cravache Lamp Single
B7218540
131x8 cm

TYPE

Wall/ Pendant Lamp

MATERIAL

Glass Fiber

CORD LENGTH

2,80m

SWITCH

No

LIGHT SOURCE

E14

MAX WATT

25 Watt

MAX VOLT

240 Volt

LAMP

Not included

CERTIFICATION

Class I

ENVIRONMENT

Indoor

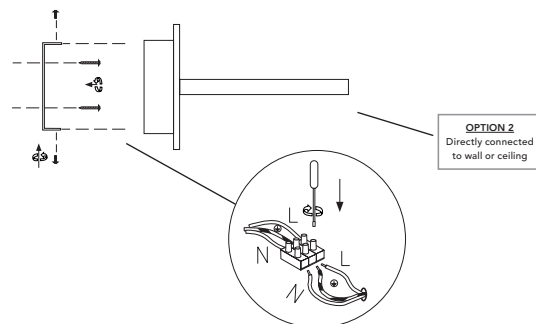

OPTION 1
Used with plug

OPTION 2
Directly connected
to wall or ceiling

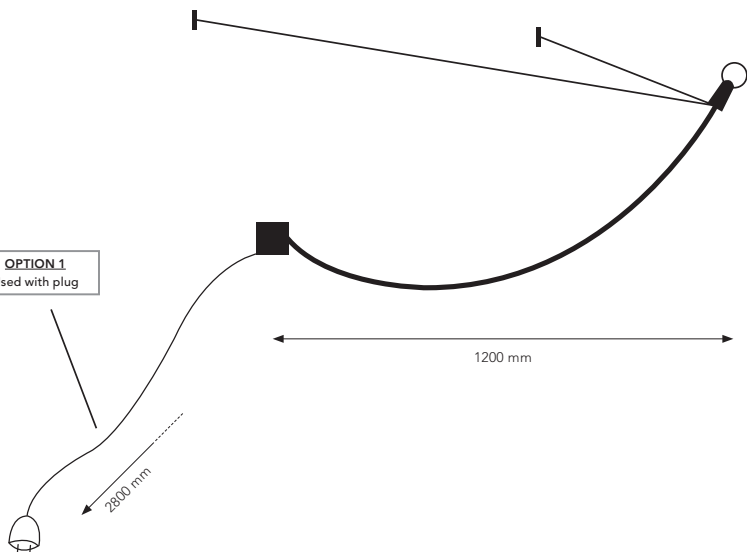

CRAVACHE LAMP

Paulineplusluis

SERAX

PRODUCT INFO

Cravache Lamp Triple
B7218541
131x20 cm

TYPE

Wall/ Pendant Lamp

MATERIAL

Glass Fiber

CORD LENGTH

2,80m

SWITCH

No

LIGHT SOURCE

E14

MAX WATT

25 Watt

MAX VOLT

240 Volt

LAMP

Not included

CERTIFICATION

Class I

ENVIRONMENT

Indoor

