

PODS

Within open plan office environments it is more common today for employees to share resources such as printers and scanners. Aside from the general ambient noise of an office it is

generally accepted that it is these kind of devices whirring into life that provide much of the acoustic and visual distraction of colleagues utilizing them.



DESIGN

Senator

Our team of talented in house designers are responsible for creating elegant, innovative furniture designs which not only look beautiful, but minimise the impact on the world around us.

They come from all over the world, but are based in our Design Center located in a quiet Lancashire village just outside the Ribble Valley. Our dedicated facility is over three floors which include studios, a materials test center and prototyping lab.

STANDARD FEATURES (*Selected models only)

- Internal steel frame with multi layered foam construction
- Vertical panels upholstered in Camira Blazer fabric (two-tone standard)
- Quick release panel connector system
- Leveling adjusters
- 1" TFL work surface*
- Integral under work surface vertical cable management*
- Integral seat and back rest*
- Center panel able to support monitor*
- Low voltage LED task light*

OPTIONAL FEATURES

- Dart accent color
- Integral work surface power including 1 Power, 2 USB, grommet mount with a 72" cord
- Integral work surface power including 2 Power, 2 USB, clamp mount with a 72" cord
- Coat Hanger
- Name Plate
- A2 / A3 Magnetic dry wipe board
- Two-tone upholstery
- Choice of finish options available (See finish page)

DIMENSIONS

MID HEIGHT AND FULL HEIGHT

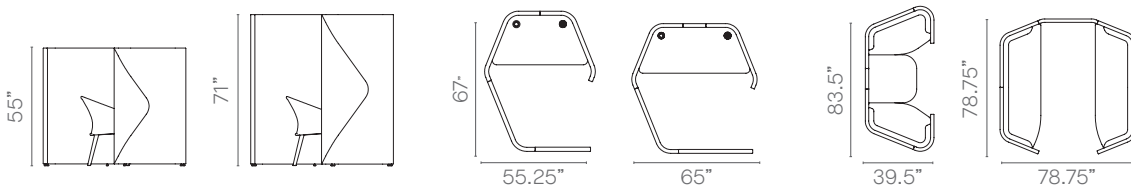

TEAM

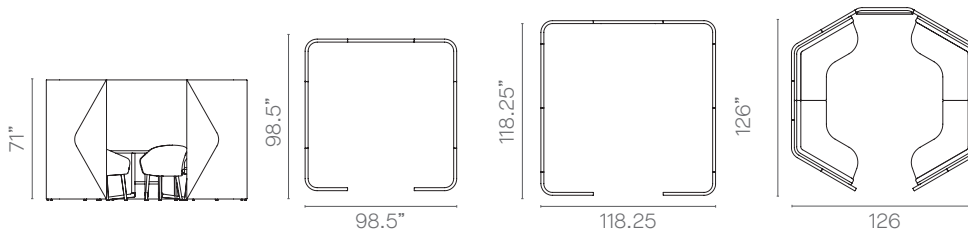

SOLO ABODE

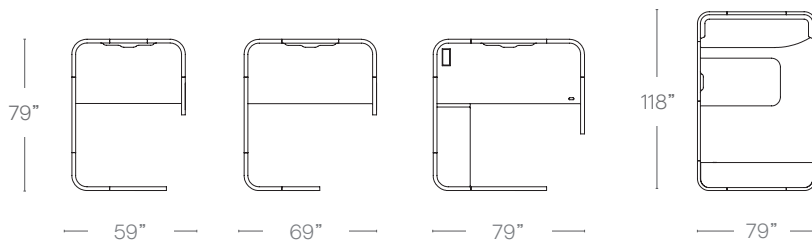

DUO & QUAD ABODE

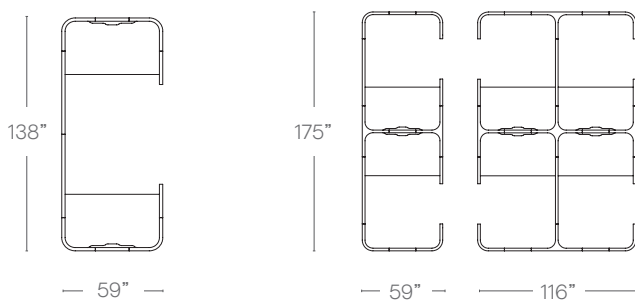

DIMENSIONS

MID HEIGHT AND FULL HEIGHT

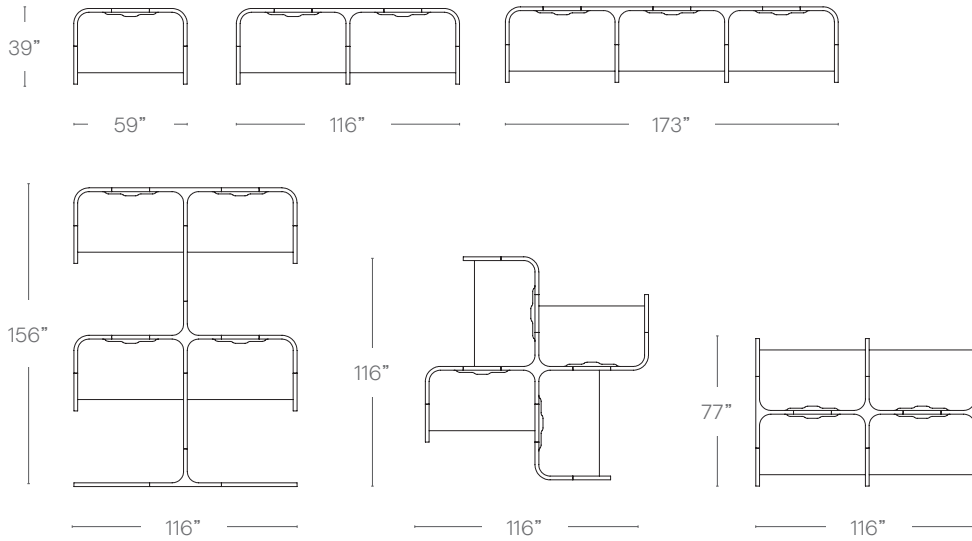

TEAM

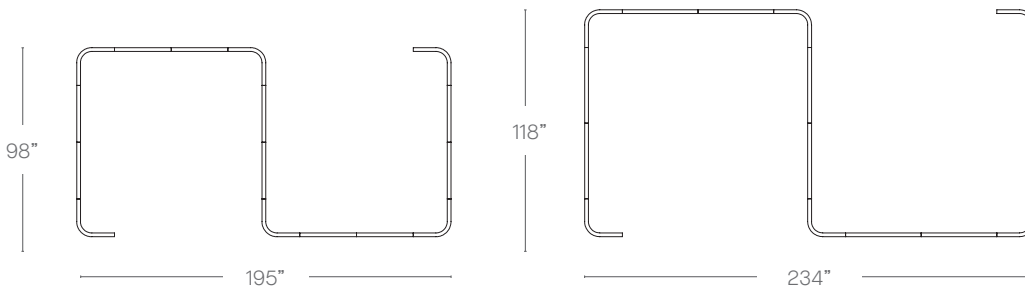

RESOURCE CORRAL & WALL

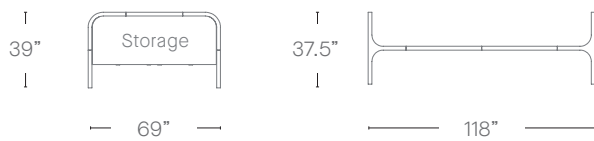

MATERIAL CONTENT

Components are constructed of the following

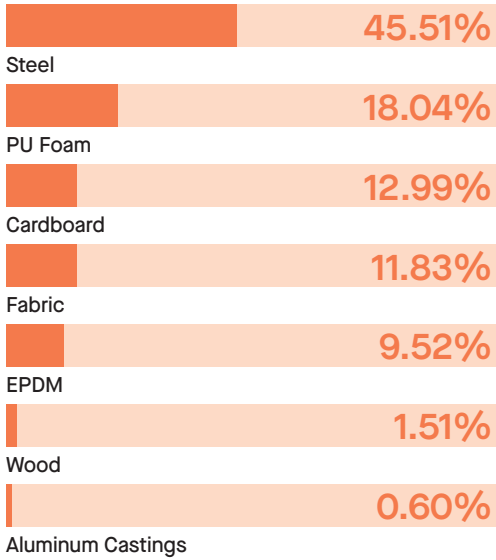

RECYCLED CONTENT

Contains up to 39.75% of Recycled Material

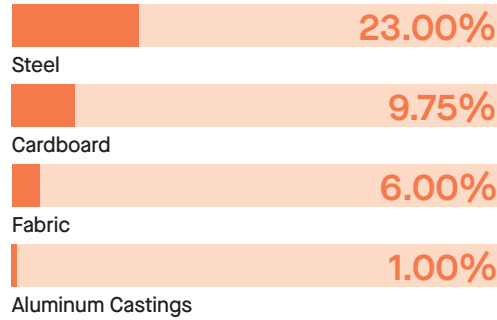

RECYCLABILITY

The range is 99% recyclable

99%

SENATOR 3 R'S

Senator is committed to continually improving the sustainability of all environmental aspects within our business.

To meet both international standards and our own environmental targets we apply the three R's principle

-Reduce, Reuse and Recycle.

Whilst recycling is the element which receives the most exposure it is actually the last option available and should never be the prime target in anyone's battle to reduce waste.

It is our duty as individuals and as a company to initially attempt to **Reduce** usage. Then we should look to **Reuse** wherever possible and finally, only after these two processes have been exhausted, should we consider **Recycling**.

REDUCE REUSE RECYCLE

FINISH OPTIONS

- 1" TFL work surface (standard)*
- Integral work surface power and dual charger USB 72" corded available in Silver, Black or White (optional)*
- Name plate available in Black or White (optional)

A2 (24" x 18") magnetic dry wipe board with hanger available in Black or White (optional)

A3 (18" x 13") magnetic dry wipe board with hanger available in Black or White (optional)

Pod products can be upholstered in a select range of fabrics from Senator's standard upholstery collection

CAMIRA BLAZER FABRICS – More available



Plymouth

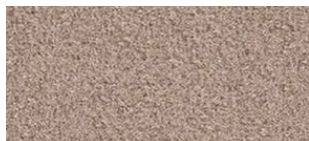

Fairfield



Latymer



Silcoates

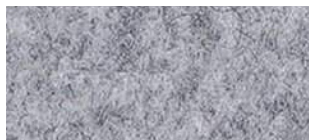

Silverdale



St Andrews



Trevelyan



Ulster



Wellington



Wesley

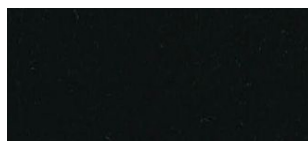

Napier

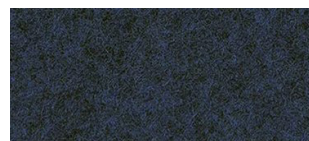

Newcastle



Newport

TFL FINISHES

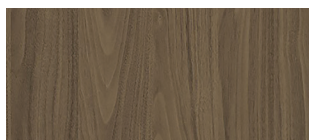

Carini Walnut

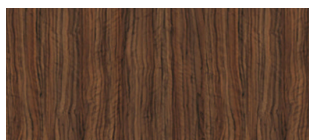

Mocha



Autumn



Strata Oak



Maple



Highland Oak



Winter Oak

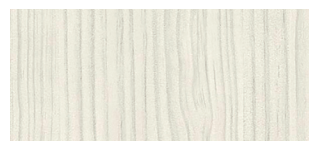

Hacienda White

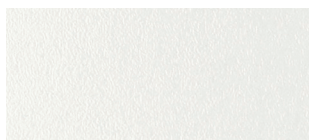

White

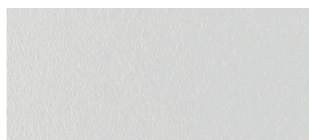

Light Grey



Denim



Clay

FRAME / LEG FINISHES



Black



White