

Family
Saga

Design – Alexander Lervik



JOHANSON



Introduction

Close long-term collaboration between Alexander Lervik and Johanson has resulted in numerous successful products over the years. This spring Alexander makes his mark in our product portfolio once more with the launch of Saga

Alexander has based his design on the classic café chair to make sure the result will work well in a wide range of settings and situations.

Saga is stackable and all the backrests are designed so that the chair can easily be hung from a table or desk to make cleaning easier.



Designer

Alexander Lervik is one of Sweden's most well-known designers, collaborating with a number of national and international producers, including Moroso, Zero, Designhouse Stockholm and Johanson. Though his main focus is lighting, furniture and product design, he also creates concepts for hotel and restaurant interiors and collaborates with fashion brands.



Models



Saga 08-46 Classic



Saga BS 65 Classic



Saga BS 80 Classic

Material

Back - Wood



Oak



White stained oak



Black stained oak



Oak veneer stained in any RAL color

Seat - Upholstery materials

Johanson offers a very generous range of fabrics, leather and artificial leather from the most reputable suppliers in the world. Should any other material be desired despite the wide selection, it is also possible to suggest other materials. Johanson does not charge start-up costs for handling non-standard materials

Multicolour - Finish RAL

Take part in Johanson's color range, 400 variants of different finishes are offered as standard on steel frames and metal details. Choose from all 192 RAL colors, alternatives are available both as solid finish (gloss 72) or Structure finish which has a matte, slightly textured elegant surface. In addition, 15 RAL colors with pearl finish and chrome are offered.

For all colours see www.johansondesign.com

192 Solid collection (gloss 72)

192 Structure collection (matte, textured surface)

15 Pearl finish collection and chrome.



Facts

Saga in detail

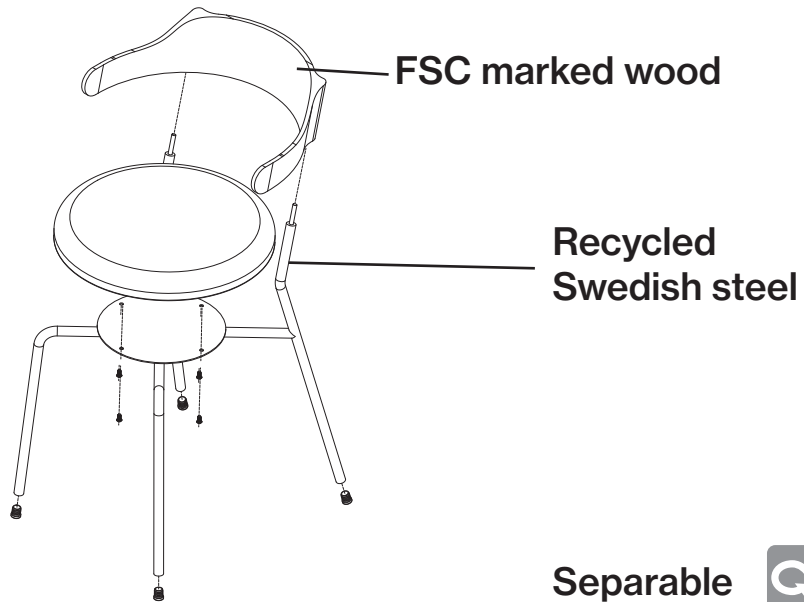

Material

- Recycled Swedish steel
- The seat is made in moulded CMHR foam (density 65kg) that meets the highest requirements for flammability (CMHR quality).
- The base is made of finished/lacquered metal.

Certificate - Saga

- Fire certificate (BS EN 1021-1 & 2)



Recycling

All steel parts are recyclable. Before we finish the chrome/lacquer all grease/oil is removed by alkaline wash and then sent for destruction. The lacquering is produced by electrostatic epoxy powder coating that gives a minimum of waste. The electrostatic chrome (chrome 3) is recyclable. The plastic parts that are used are recyclable by grinding. All upholstery and frames of synthetic material are totally without C.F.C. emissions. All glue is water based.

Material declaration

For more information about the product please download material declaration on our website, under Downloads à Product Information at www.johansondesign.com

BIM - objects can be downloaded at johansondesign.com



3D Max



Autocad 2D



Archicad



Autocad 3D



Revit



Sketchup

 pCon

Facts

Measurements cm

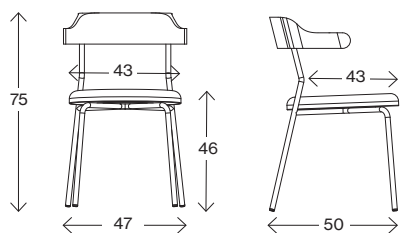

Saga Classic

Weight (kg) 5,8
Volume (m³) 0,21



Measurements cm

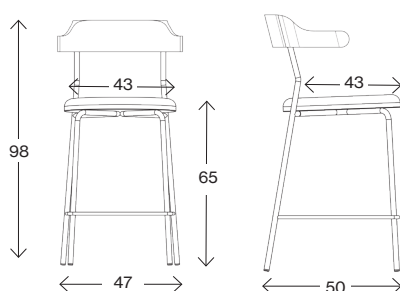

Saga BS Classic 65

Weight (kg) -
Volume (m³) 0,21

Measurements cm

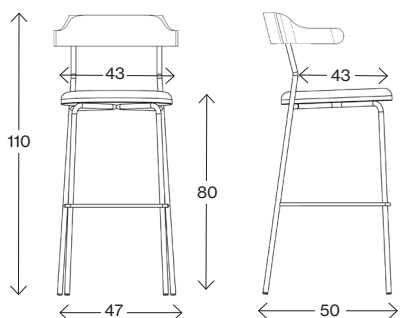

Saga BS Classic 80

Weight (kg) -
Volume (m³) 0,21



JOHANSON

Johanson Design AB | Anders Anderssons Väg 7 | 285 35 Markaryd | Sweden
Tel +46-433 725 00 | www.johansondesign.com